

LEARN HOW TO INCREASE
VOLUME OF BUSINESS BY IM-
PLYING RFID TECHNOLOGY!



CONTENTS

- 1 SAAB USES RFID FOR ROUNDING ON TRESTLES
- 2 HOW A "DEAD" PRODUCT GETS NEW LIFT
- 4 AHLSELL IS INVESTING AGGRESSIVELY IN RFID
- 6 TAMING THE TANGLED LOGISTICS OF A GROWING INDUSTRY
- 8 RFID NETWORKING SEMINAR 13 MARCH AT KTH, KISTA
- 9 RFID TEMPERATURE LOGGER
- 10 ROLLOUT OF RFID READERS BY TRAFIKVERKET IN SWEDEN
- 11 RFID TAG FOR RETAIL EPC PROGRAMS
- 12 MERGER BETWEEN PHYSICAL AND LOGICAL ACCESS
- 14 U.A.E CHAIN REALISES TREMENDOUS ECONOMIES WITH RFID
- 16 TRANSFILTER - BRIEF DESCRIPTION OF THE COMPONENT
- 18 RFID APPLIED IN STORM-WATER FILTERING SYSTEMS
- 20 TECHNOLOGY AND STANDARDISATION
- 22 THE MORPH STICKS
- 24 THE GOLDEN TAG AWARD 2012
- 26 RFID IN EUROPE - FUTURE OUTLOOK 2018-2023, SURVEY

SSAB USES ADAGE RFID SYSTEM FOR ROUNDING ON SSAB'S TRESTLES

SSAB now meets all safety and service requirements for its trestle handling thanks to the RFID system.

BRIEF SUMMARY OF THE PROJECT:

- Patrolling of > 500 trestles
- Software for data collection developed by Adage
- Integrated with IFS system
- Work orders are created automatically in the IFS system from rounding results
- Hand Readers Nereid
- passive tags HID 50mm

RESULTS:

- Correct number of trestles in IFS system (ie on correct stock / inventory of trestles)
- Proper ID on all trestles
- Follows the law concerning inspection
- Can plan maintenance and inspection in a structured way

WORKING PROCEDURE:

- Work scheme in IFS is created on the items that should be inspected
- All objects belonging to the work order is transferred from the IFS database to the RFID application developed by Adage
- A link between objects and RFID identity can also be made in the application.



- Rounding is done and the data is stored in RFID hand reader
- After rounding the RFID hand reader is placed in the docking station
- Data is transmitted via the RFID application to the IFS system
- IFS creates work orders if necessary, otherwise complete selected objects in the IFS systems work order.

For more information please contact:

*CEO & Market
Anders Hermanson
anders.hermanson@adage.se
+46 (0)70-266 96 36*

HOW A “DEAD” PRODUCT GETS NEW LIFE, HELPING CUSTOMERS OPTIMISING TOTAL COST OF OWNERSHIP



The black RFID reader (above left) had been produced and sold by the Baumer Ident company for many years. It had been widely accepted by customers, not only in Europe, but also in many countries abroad. In the middle of the year 2006, Baumer Ident was sold and a few years after the take-over, the new owner decided to discontinue the LF line of products and only concentrate on UHF products.



Now many customers were faced with a big problem, when replacements or repairs were needed, or when present installations needed expansion. Since LF systems came on the market already in the 70's, standardisation was not a big issue. Each manufacturer had his own way of handling the communication and energy transport between the reader and the transponder. The only thing that was common was the frequency - 125kHz.

Repairing old equipment was not possible, since some components were no longer available on the market. Expanding present installations would mean completely new equipment and new software, or at least very costly re-programming.

Last year we were approached by some customers, asking if we could not find a solution to the predicament of not having an equivalent to the Baumer reader.

The development of a totally new reader from scratch, was not an alternative, since it would incur too high costs.

Hence, we set out to scan the market for a suitable reader we could use as a base for a conversion. Having tested quite a number of different systems, we finally settled for a suitable reader we found in Germany.

It had the main criteria we needed, 2-channels to drive two separate antennas, all interface types we needed

i.e. RS232, RS485, RS422, Profibus DP and Ethernet/IP. Further and not the least important, the company was willing to cooperate with us to carry out a re-programming of their original command structure and substitute it for the Baumer commands.

This means that our customers will be able to use the new reader 1:1 without having to carry out any changes to their computer programs.

To further facilitate the integration of the new reader into existing systems, we have equipped the front of the reader with identical connectors as those that were installed on the Baumer reader.

>>

An additional positive feature was a change to the antenna circuitry, so that the Baumer antenna design could be kept unchanged.

The new reader can thus substitute a defect old reader without having to carry out any changes at all.

Let us take a closer look at some of the hardware changes we made, to make the conversion possible.

The first and obvious change was to find a way to change the communication connectors from the more modern M12 type back to the older configuration, using D-Sub connectors.



ORIGINAL COMMUNICATION BOARD.

By introducing a conversion board, we transferred the signals to the way they were arranged at the old Baumer reader's D-Subs.

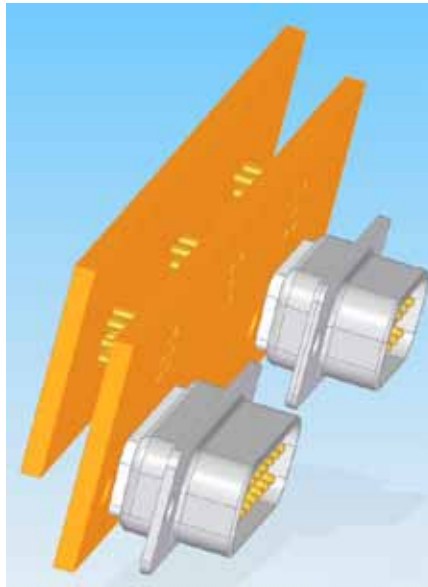

SCHEMATICS OF THE TRANSFER BOARD.

Being a more modern design, the new reader engine offers some additional features, that were not available back when the Baumer reader was designed e.g:

- USB service interface Integrated
- Web server Micro SD memory
- expansion Integrated temperatur sensor

THE MAIN READER BOARD

By utilising existing hardware, but only making necessary changes and additions, it has been possible to develop a "new" reader within a very short time and keeping development costs at a moderate level.

The life span of the presently installed product base has thus been extended and will improve the customers' TCO considerably.



For more details please contact:

Bob Forslund

AMC HB

bob@amc-hb.se

or

Roland Karlsson

Ident Service AB

info@identservice.se



AHLSSELL IS INVESTING AGGRESSIVELY IN ITS LOGISTICS NEW RFID SYSTEM

When trading group Ahlsell began using a system with RFID tags (Radio Frequency Identification) on their load carriers and RFID gates at the loading ports, they reduced the loading errors and reduced costs significantly.

Ahlsell is a fast-growing group in the plumbing, electrical, tools, machines and refrigeration products for professional users. Each year the company delivers 5.5 million parcels in Sweden. A considerable volume with high demands on precision, punctuality and efficiency in logistics. After long time

using internal solutions Ahlsell chose to try something external and tagged its load carriers with RFID tags and implemented RFID gates in all of their loading gates. The specific RFID solution that Ahlsell chose was delivered by the company Vilant Systems who has a comprehensive solution that

provides a complete solution including hardware, software and installation.

- RFID readers and antennas installed at the loading gates and the tags on the load carriers are read and verified automatically by using our software at each loading gate, explains Peter



The system has met the expectations and now Ahlsell is planning to roll out the solution also to Norway during 2013 and then to Finland.

Hietala, Country Manager of Vilant Systems in Scandinavia.

The RFID tag attached to the freight carrier contains a returnable asset identifier developed by GS1, also called a GRAI (Global Variable Returns Asset Identifier) that identifies each load carrier and makes it easy to follow and track on individual level. Vilant RFID gates automatically identifies all cargo carriers when passing loading gates, while Vilants System software check their status and position.

- The automation and efficiency that this system provides, facilitates the handling of large volumes. The number of errors is drastically reduced and visibility increases, adds Peter Hietala.

If a faulty load carriers passes an RFID gate Vilant trigger a loud sound alarm in order to eliminate any delivery failure and additional costs.

FROM BARCODE TO RFID

At Ahlsell central warehouse and logistics hub in Hallsberg near Orebro and 150 trucks arrives and departs

daily. Via 35 cross docking hub the goods is loaded on 1200 plastic bins, 1000 plastic pallets and 250 steel scaffolding. The logistic scale requires a well-functioning system and before Ahlsell started to use RFID technology, the load carriers was monitored with their own system based on barcodes. Barcode solution required manual scanning and but could not gain control over where the missing individual load carriers were sent and when. Sometimes deliveries ended up in wrong destinations with unhappy customers and costly corrections as a result.

“- Barcode had, unlike RFID system, really only one function, to check what we have sent,” explains Daniel Johansson, Logistics Manager at Ahlsell.

After the installation of the RFID system, there are displays with Vilants software at each loading gate in Ahlsells warehouse in Hallsberg.

On the displays you can see the gate loading window based on the automated loading schedule for each departure. The effects of the system

are significant; last year Ahlsell had 110 boxes sent to wrong destination containing packages to several customers. Since the implementation of the RFID system there has only been one delivery error. Today Ahlsell knows exactly how long each asset has been outside the warehouse and if it's not returned in time, the carriers have to replace them.

The main advantages with the RFID system is the automated quality control and monitoring function, Daniel Johansson summarizes.

The system has met the expectations and now Ahlsell is planning to roll out the solution also to Norway during 2013 and then to Finland.

*For further information please call:
Peter.Hietala@vilant.com*

TAMING THE TANGLED LOGISTICS OF A GROWING INDUSTRY BAAS PLANTENSERVICE

IMPLEMENTS NORDIC ID SOLUTION

Imagine 15,000 trolleys loaded with plants coming from 400 suppliers, getting repacked and shipped out to 350 different shops in the space of a single day. That's the situation at Baas Plantenservice's horticultural distribution centres in Holland during peak season, from March to May. Now imagine keeping track of those comings and goings with clipboards, telephone calls and email.

CROSSING THE DIGITAL DIVIDE

Until recently, horticulture distribution powerhouse Baas Plantenservice relied heavily on paper lists, which were then transcribed into a database. "The process inevitably involved some human error," says Edwin van Lenthe, Logistics Manager at Baas. "But there was also a lag in getting information from paper into our computer system. A one-hour delay, when you've got hundreds of trucks rolling in, is a problem."

In January 2011 Container Centralen,

the company that provides trolleys and trolley maintenance contracts to greenhouses, rolled out an initiative tagged 'Chip It'. The undertaking saw the company tag more than 3.5 million trolleys across Europe with EPC Gen 2 passive ultrahigh-frequency (UHF) RFID tags. Container Centralen wanted better control over its trolleys — the industry standard in the horticulture market. Baas Plantenservice took one look at the new trackable trolleys coming into its facilities and saw an opportunity for its own operations.

Convinced of the efficiencies of RFID and encouraged by an influx of tag-carrying trolleys — an investment borne by Container Centralen—Baas Plantenservice decided to set up a pilot program. They enlisted the assistance of Dutch systems integrator Mieloo & Alexander, who set up their Scan Green RFID Supply Chain Platform, as well as Qurius, ERP integration experts. To feed the system they used Nordic ID Merlin and Nordic ID Morpheic mobile computers with cross dipole antenna and RFID/barcode scanning capability.



“Our development team has truly mastered the devices, and also Nordic ID support is very good.”

NORDIC ID THE PREFERRED PARTNER

Sander Merckx, Director and Partner at Mieloo & Alexander, says his company chooses to work with Nordic ID when the decision is theirs to make. “We’ve involved Nordic ID on maybe 15 projects since the end of 2007. Their devices demonstrate consistently reliable reading behaviour, which is very important for user operated scanners,” he says. “Our development team has truly mastered the devices, and also Nordic ID support is very good.”

Baas Plantenservice implemented the pilot during the summer of 2011 in collaboration with four of their main growers. These suppliers were provided with Nordic ID Morphic mobile computers running Mieloo & Alexander’s Scan Green RFID Picking software. Growers would scan products to associate them with trolley tags. Data was then sent by Wi-Fi, UMTS, or cradle to the ScanGreen Supply Chain

platform, which passed it on to the ScanGreen receiving application running at the server level and on Nordic ID Merlin mobile computers at BAAS distribution centres. Once trolleys were scanned on the receiving dock and the data was verified against that which growers had scanned, the information was passed on to BAAS’ ERP system.

Receiving trolleys at BAAS is now an efficient process requiring nothing more than a quick scan of each trolley with Nordic ID Merlin mobile computers. “Before, trolley control from grower to distribution centre and back again was effective but not efficient,” says van Lenthe. “Now it’s both.”

Supply chain transparency boosts profit

In January 2012 Baas began working with 50 of their most important growers, representing 50% of inbound

volume, to track inbound trolleys and take advantage of the tags they carried. “When trolley administration is completed automatically it saves growers time as well,” says van Lenthe. “The system creates a more transparent, faster supply chain, helping to increase profit margin. Certainly, growers that participate will share in more revenue.”

The next stage of the roll-out has already begun. It involves streamlining the flow of goods between BAAS Plantenservice and customers in Germany as part of the German-Dutch Interreg IVa Project RAAS (RFID Application And Support). In addition to increasing the visibility of the flow of goods, which will enable new collaboration potential in the near future, BAAS Plantenservice also expects to gain better control of returnable assets between supplier and retail operations. As this is a pain point for many suppliers, a proven solution will definitely generate a lot of interest!

*For further information please call.
mirva.saarijarvi@nordicid.com*



RFID NORDIC AND KTH IPACK CENTER IS HAPPY TO PRESENT

RFID NETWORKING SEMINAR

IN KISTA, 13 MARCH 2013 AT KTH ELECTRUM, ISAFJORDSGATAN 20-26, TRAPPH. C (KA-C1) KISTA – STOCKHOLM

THE PROGRAM

09.30	Registration and display area open	
10.00	RFID - Welcome and background	Ove /Lucas RFID NORDIC
10.20	RFID standards	Olle Hydbom, AutoID experts
10.40	RFID in Security	Zsolt Noveczki Loxtore RFID System
11.00	coffee	
11.20	New RFID cases from Finland	Hielke vanOostrum/AlexanderAmonoff
11.40	Tag in size of chip	Mr. Akira Nagase Hitachi Japan
12.00	RFID	Guided tour IPack Lab. / LUNCH
12.40	Low power sensors for RFID	Cristina Rusu, ACREO
13.00	RFID in Industri	Jos Klein Woud, Siemens
13.20	iPack center at KTH	Prof. Axel Jantsch
13.40	RFID in waste water filtering	Niels-Ander Dannrup, CamTech AB
14.00	RFID in Trade	Niklas Hild, Microtracking
14.20	RFID in harsh environments	Anders Hermansson, BnearIT
14.40	RFID in CarSharing, Seou South Korea	Prof. Jongtae Rhee, Dongguk Univ.
15.00	coffee	
15.20	RFID in guns and rifles	Dr Ing. Kebo Vladimír VSB Ostrava
15.40	New Compatible RFID reader	Bob Forslund, AMC
16.00	Information about RFID in Europe	Ove Canemyr, RFID NORDIC
16.20	Annual meeting RFID NORDIC	All Members from RFID NORDIC

YOU ARE MOST WELCOME TO CONTACT US

Free entrance. But please make registration at:
 ove.canemyr@trendsetter.se +46 70 794 09 87 or
 lucas@retorium.com +46 70 182 1500





RFID TEMPERATURE LOGGER

ADVANCE INFORMATION D14TEMP01

FEATURES

- Fully compliant up to ISO 14443A-4 (ISO 15693 option)
- Temperature accuracy: $\pm 0.5^{\circ}\text{C}$ (abs), $\pm 0.1^{\circ}\text{C}$ (relative)
- Temperature range -30°C to $+100^{\circ}\text{C}$
- Fully configurable temperature logging profile
- 16 bits linear low-offset instrumentation $>?$ ADC
- 10 K samples storage capacity
- SPI master interface for auxiliary slave
- Optional ultra low power crystal clock
- MSP430 CPU with debug interface
- Can be operated with and without battery power
- Firmware upgradable
- Ultra low power tag storage mode ($< 0.1\mu\text{A}$)
- DES encryption hardware support
- Available as Tested Dies (KGD) or in QFN

DESCRIPTION

The DELTA Microelectronics D14TEMP01 is an ISO 14443A transponder chip (PICC) that performs and stores temperature measurements with a configurable time interval (0.1s to 10h).

The start of the temperature logging can be delayed. The total logging capacity is 10 K samples, each with a precision of 16 bits. Data transfer rate is up to 848 kb/s and the UID is configurable up to 10 bytes. With a credit card size antenna, operation up to 10 cm from reader is possible.

For autonomous temperature logging the device is mounted with a 2.7 – 5.5V battery. When no temperature measurement is performed standby current consumption is below $1\mu\text{A}$. When an RF field is applied, the internal power supply switches to power extracted from the RF field. This way, data from the memory can be accessed even with an expired battery. The chip can also supply 2.7 – 5.5V to an auxiliary slave. The embedded EEPROM memory size is 32k bytes. Apart from temperature data and default drivers, it can also hold custom SW applications. It is therefore possible to use the chip for accessing and controlling auxiliary SPI components. Guard banding is possible yielding a warning if the temperature has been measured outside the guard band. Tamper detection e.g. revealing if a wire has been broken, can also be supported. DES hardware encryption is available for data privacy.

POSSIBLE APPLICATION AREAS

Temperature logging for temperature sensitive objects/ parcels or RF interface to various SPI controlled sensors e.g. pressure, tilt voltage, light etc. An auxiliary differential input to the $>?$

ADC can support an additional external analog sensor.

For further information please contact
 Gert Jørgensen – gj@delta.dk
 Gunnar Bjarne Andersen – gba@delta.dk

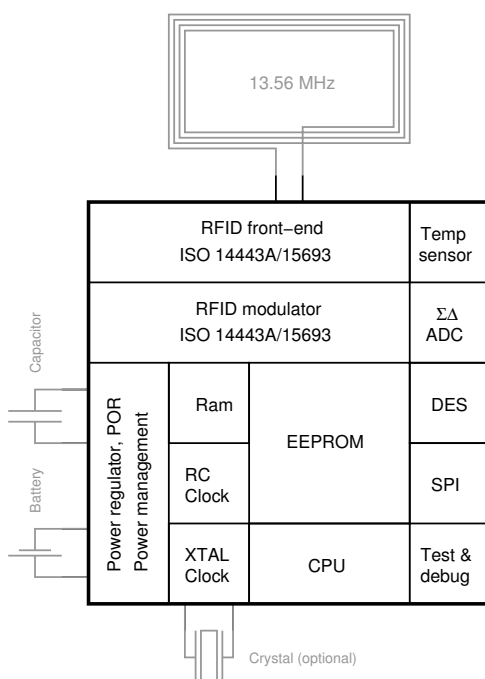

TAGMASTER CONFIRMED AS SUPPLIER FOR CONTINUED ROLLOUT OF UHF RFID READERS BY TRAFIKVERKET IN SWEDEN

TagMaster, a producer of advanced RFID solutions for railway applications, has received additional orders for the XT-3HD long-range RFID reader from Trafikverket

TagMaster, a producer of advanced RFID solutions for railway applications, has received additional orders for the XT-3HD long-range RFID reader from Trafikverket (the Swedish Rail Administration). This follows the successful verification by Trafikverket of the performance of the XT-3HD reader's in the field. The first readers were supplied to Trafikverket at the end of 2011 under the supply contract issued to TagMaster and its system integrator Swarco. The RFID readers are being rolled out by Trafikverket as part of its nationwide system for tracking goods wagons as they pass detection sites on the Swedish mainline rail network. TagMaster will deliver additional XT-3HD long-range RFID readers to Trafikverket which are fully EPC Gen 2 (ISO 18000-6C) compliant. The XT-3HD is the heavy-duty model of TagMaster's XT-series of UHF readers and is certified to the requirements of the demanding railway environment. The XT-3HD is based on TagMaster's existing fourth generation reader technology and includes an open architecture Linux operating platform. To enable the detection of untagged wagons, axle counters have also been interfaced directly to the XT-3HD reader in this application. TagMaster continues its co-operation with organisations such as Trafikverket

and GS1 in order to promote the use of EPC Gen 2 (ISO 18000-6C) compliant readers and tags for this railway wagon tracking application. Trafikverket, along with several other infrastructure owners in Europe are implementing RFID wagon tracking systems and by specifying the use of an ISO standard, they will provide interoperability over borders for the various stake holders across Europe.

"We see this additional order not only as confirmation that the concept Trafikverket has selected is working well, but also that our RFID readers have met the tough requirements needed in the railway environment. We are very pleased to continue our co-operation with Trafikverket and we will continue to target this wagon tracking application in Europe and expect to see further interest from infrastructure owners and operations over the coming year", says Richard Holt, Director of Transportation at TagMaster AB.

For further information, please contact:

Richard Holt, Director of Sales for
Transportation

Phone: +46 8 632 1968

E-mail: richard.holt@tagmaster.com

SMARTRAC LAUNCHES WEBLITE UHF RFID TAG FOR RETAIL EPC PROGRAMS

SMARTRAC a developer, manufacturer, and supplier of RFID transponders and inlays, has announced the introduction of its new UHF EPC compliant WebLite inlay.

The SMARTRAC WebLite inlay represents a technological advance in both size and performance. With an antenna size of only 46 x 15 mm (1.8" x 0.6"), it is especially suited for item-level tagging and identification where RFID tag space is limited and performance is of critical importance.

Due to its compact form and special design, which takes into account RF requirements for close coupling and high population RFID scanning, the SMARTRAC WebLite perfectly meets the needs of retail apparel applications. Close coupling occurs when RFID-tagged items are stacked in close proximity to each other. SMARTRAC has been working with its partners, renowned independent test facilities, major retail end users, and RFID hardware providers, to test, qualify, and approve the WebLite tags and inlays for immediate deployment in major item-level tagging applications.

"The new SMARTRAC WebLite is an important next step for item level identification in retail. As EPC tagging expands to a wider range of consumer products, reduced tag size without compromise in performance has become very important", says Michael Teitelbaum, CEO of r-pac International Corporation. "We are pleased that we are able to deliver the new EPC tagging solutions to retailers and their brand suppliers based on our close cooperation with SMARTRAC. The industry has been demanding a small

format tag, such as the WebLite, that meets the most challenging tagging situations. The WebLite meets the technology needs of the industry by performing on a wide range of products from denim to kitchen electrics – while maintaining a small form factor."

"Our new WebLite inlay is the result of our close collaboration with and commitment to our partners as well as our goal of understanding the needs of end users, retailers, and brand owners in their quest for significantly improved merchandise visibility enabled by RFID technology. Working with r-pac has allowed us to take application requirements from end users, turn them into a product concept, and, in a very short period of time, validate and approve this concept in the form of a new product, the SMARTRAC WebLite," said Wolfgang Schneider, Member of the Management Board and Head of SMARTRAC's Business Unit electronic Product Identification (ePI).

Technical features of the SMARTRAC WebLite with Impinj Monza™ 5 IC:

Antenna size of 46 x 15 mm / 1.8" x 0.6"
128-bit EPC, 48-bit serialized TID
Especially suitable for item-level retail, logistics, and supply chain applications

The SMARTRAC WebLite is currently available. High-volume production started at the end of November. The WebLite has gone through stringent performance testing by major U.S.

retailers with RFID programs and has passed these tests for a multitude of product categories. The WebLite is available in converted, fully printed, and encoded form through r-pac and the r-pac worldwide service bureaus.

The new WebLite products will also be displayed at the SMARTRAC booth (#2059) at the NRF 102nd Annual Convention & EXPO from January 13 to 15, 2013, at the Jacob K. Javits Convention Center in New York City.

If you have any questions about SMARTRAC, please contact:

Tanja Moehler
Head of Corporate Communications & Marketing
SMARTRAC N.V.
Phone: +31 20 30 50 157
tanja.moehler@smartrac-group.com
Internet: www.smartrac-group.com
Twitter: <http://www.twitter.com/SMARTRAC_NV>www.twitter.com/SMARTRAC_NV

If you have any questions about r-pac, please contact:

Paul Arguin
Director of RFID Development
r-pac International Corp
132 West 36th Street, NYC 10018
Phone: +1 212-465-1818 /
+1 978-725-5919
Email: paul.argin@r-pac.com
Internet: www.r-pac.com

MERGER BETWEEN PHYSICAL AND LOGICAL ACCESS

- PAS CARD AND NEXUS WANTS TO REVOLUTIONIZE THE SECURITY BUSINESS

On the 24th of August Nexus and PAS Card merged and are now part of the same parent group. The fusion brings physical and logical access closer together. The companies aim is to offer the market cost effective, entirety solutions from the same supplier and revolutionize the security business with new, open solutions.

Through open solutions that are not tied up to a specific supplier Nexus and PAS Card will take security one step further. The companies look to offer something that the security business is demanding.

– Our products and competence form a unique offer that makes the processes more efficient for our customers, when it comes to both physical and logical access. We are going to be the best alternative when it comes to combining physical and logical access, says Peter Gille, CEO of Nexus.

Nexus is one of the leading companies within authentication and identification, and has with its innovative solutions enabled easy access to various services for over a 100 million users. An extended product portfolio, where logic access is tied together with physical access, will make it possible for our customers to use the same access to a door as well as to the company network and cloud services. By com-

binning these two worlds Nexus will be able to raise the security and increase the accessibility and make it easier for the user. The Nexus Group has earlier acquired the software company vps, which specialize in software for physical access. PAS Card is the leading company on the Nordic market within ID Solutions and has a concept for physical access that complements what Nexus offers.

The fusion of the two companies results in a group with 160 employees, a turnover of a quarter of a billion, fourteen offices in eight countries where the solutions are used by over 25 000 customers. The merge between the companies comes in a time when there is a strong tendency to integrate the physical and logical access on the market.

– We will be able to offer open unique solutions, without tying the customers to one specific technique, which we believe is the key to success. We

want to take the leading position on the global market and offer broad solutions that are missing today, says Freddie Parrman, MD PAS Card.

PAS Card has since the start 2006 been one of the most prominent companies on the Swedish security market. Their concept for physical access will now be exported outside the Nordic countries with the offers that Nexus has in their portfolio. A fusion with Nexus, who is ranked as one of the leading companies within secure access solutions, is a new course. Freddie Parrman and Peter Gille are both convinced that this new course is the right way to be able to offer what the customers request in the future.

– We have unique products and unique competence within the two companies. Together will we be able to create innovative and efficient solutions.

For more information, please contact:

Peter Gille, CEO Nexus, 070-825 00 14, e-post: peter.gille@nexussafe.com
Freddie Parrman, MD PAS Card, 08-685 45 65, e-post: freddie.parrman@pascard.se



LearningWell

OUR WELL - YOUR SOLUTION



Please contact:
Gunnar.Ivansson@learningwell.se



NORDIC ID PARTNER TECHNOWAVE

HITS A HOME RUN IN THE PERSIAN GULF

MAJOR U.A.E. CHAIN REALISES TREMENDOUS ECONOMIES WITH RFID

When Persian Gulf retail giant Liwa Trading Enterprises became aware of shrinkage in several of its stores, it looked to technology partner Technowave International for a solution.

The Abu Dhabi - United Arab Emirates - based retailer counts more than 200 stores in its network across the Persian Gulf region. 19 of those stores, exclusive to the GANT brand, were experiencing significant shrinkage. At Technowave's suggestion, Liwa decided to pilot the use of RFID in one store and upon successful trial, rolled it out to nine of those stores across the U.A.E. to help control shrinkage and increase efficiency.



SHRINKAGE HIGH, EFFICIENCY SUFFERING

Despite robust anti-theft systems, shrinkage was a known problem in the GANT stores. But with stock counts taking place only once per year, store management was not aware of the extent. The cause was also unknown, but management suspected employees who left the organization in between stock taking cycles.

Up until the pilot program was implemented, performing inventory counts had been a laborious process. Liwa would deploy a team of ten people armed with barcode scanners who would take between sixty and ninety minutes to perform an inventory count on an average of 2,800 items per store.

This manpower-intensive approach was symptomatic of similar logistics processes across Liwa's supply chain. In the daily or weekly transfer of goods from warehouse to store, for example, item barcodes were individually scanned at point of origin before each carton was sealed — an intensive, manual procedure that slowed the speed of operations. Impinj Speedway Revolution reader with Farfield antennas are installed at the warehouse to read the cartons and its contents which allows seamless dataflow to the ERP during dispatch and the same is reconciled at store with the Nordic ID PL 3000 terminals with integrated RFID reader. More than the stock count; transfers are helping Liwa to improve the efficiency significantly by using RFID technology.

TECHNOWAVE PROVIDES INTEGRATED SOLUTION

Because representatives from Technowave were well acquainted with Liwa's operations, they were able to quickly propose a solution.



With over 65 Auto ID professionals spread across the Middle East and India, Technowave is a U.A.E. -based system integrator with two decades' experience in barcode, mobility and RFID-based solutions. The company carried out a very successful, one-week pilot program involving RFID in one GANT store, and submitted ROI statistics associated with the pilot along with their proposal. Once they received the green light for a nine-store rollout, Technowave assembled the components of a complete solution.

SMARTPIN RFID TAGS

For RFID tags, Technowave selected a reusable RFID pin tag that carries a barcode in addition to RFID information. SmartPIN, from QID Solutions in Hungary, links an RFID code to the item product code with a simple scan at the warehouse level. In Liwa's case, SmartPIN integrated nicely with the retailer's existing anti-theft tags and helped them decrease the internal lifting by adding more intelligence to the security system.

Technowave's own in-house software development team created and implemented RFID middleware that dove-

tailed seamlessly with the retailer's enterprise resource management system. Once the SmartPIN barcode is scanned at checkout, the SmartPIN is detached from the database and the pin can be re-used with any other item.

ALLIANCE WITH NORDIC ID

For scanning purposes, Technowave recommended using the Nordic ID PL 3000 mobile RFID computer with a cross dipole antenna. Since the company is a preferred company to Nordic ID, Technowave technicians were already well acquainted with Nordic ID. They chose the unit because it was comparatively light, easy to handle and — most importantly — capable of reading in any orientation. In future rollouts, Technowave plans to add Nordic ID Merlin mobile computers as an update to the Nordic ID PL 3000.

RESULTS

The reduction in manpower required to perform logistical tasks was tremendous. Store inventory counts were reduced from 10 to 15 man-hours to 25 minutes. The Nordic ID PL 3000 was also found to have very quick read times for both folded as well as hanging items, with flawless 100% reading performance. Liwa Trading Enterprises has now decided to roll out RFID in other GANT stores in the region and add few more brands for implementation of RFID based inventory tracking system. Technowave has secured the contract this year for the rollout in 5 more stores in the region.

For further information please call:
mirva.saarijarvi@nordicid.com

TRANSFILTER

BRIEF DESCRIPTION OF THE COMPONENT

The component represents a low cost micro-acoustic device (2-port Lamb wave or SAW resonator) made of a thin piezoelectric film grown onto a carrier substrate. It has two functionalities, namely it is a highly efficient voltage transformer and a low loss bandpass filter (transfilter).

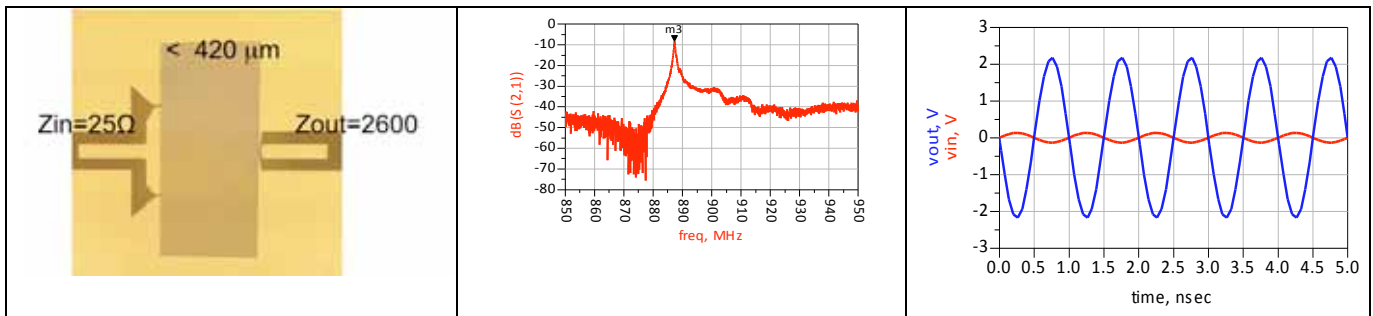

Fig.1a. Fabricated device

Fig.1b. S21 characteristics

Fig.1c. Input (red) and output (blue) voltage at center frequenc

The center frequency and the bandwidth of the component are readily varied in the range 500 MHz to 2.5 GHz. Lower and higher frequencies are also possible. Its physical dimensions are of the order of 0.5 mm² and decrease with frequency. The component is shown to readily sustain a power of 250 mW during weeks of operation. With careful design the insertion loss can be made better than -1 dB as the filter specs in intended applications are not as stringent as in telecom ap-

plications. The transformer ratio can be varied in a wide range. Equally importantly, the device can be operated in harsh environments such as high temperatures, lethal doses of radiation, aggressive atmosphere, etc.

POSSIBLE USES

To demonstrate its functionality the above measurements have been used to simulate a simple charge pump as illustrated in Figure 2a. The simulation is done at center frequency of 887 MHz.

The component can be used in various applications where efficient voltage transformation in a predefined frequency band is required. Examples are passive RFID tags, truly passive remotely triggered switches (stand-by block for TV, video, etc), passive wake up radios in wireless sensor networks, AC/DC converters, EM scavenging of EM radiation, impedance matching, etc.

As a further illustration of the applicability of the transfilter we take a closer look at how the latter can be used to

design a truly passive, addressable, remotely triggered switch (RTS) as follows. The operational principle is well described in the literature and is based on mak-

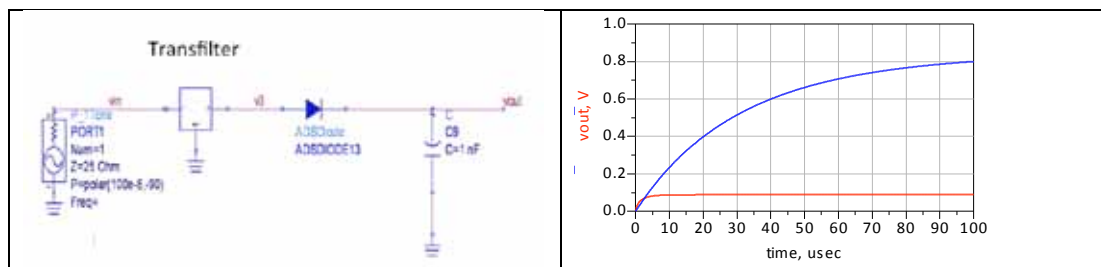

Fig.2a. Simulated circuit in ADS. Input power 100μW.

Fig.2b. Output voltage at the capacitor with and without the transfilter (blue and red lines respectively)

ing use of the energy of the interrogation signal to trigger (wake up) a sleeping device. Thus, for instance, the interrogation signal may be rectified and then used to trigger low threshold electronics. This, however, works at very short distances as the interrogation signal decays exponentially with distance. To increase range, charge accumulation and voltage transformation are typically employed as illustrated in Figure 3.

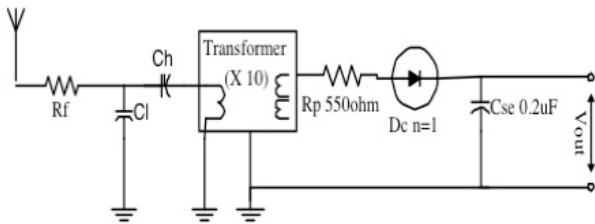

Figure 3a. A basic remotely triggered switch (FS)

Addressing is achieved by placing a bandpass filter between the antenna and the transformer. To increase the address space, a number of such switches operating at different frequencies are connected in parallel having a common logical output as illustrated in Figure 3b.

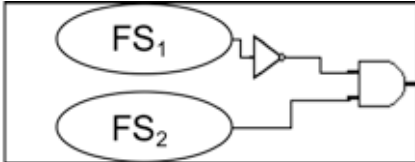

Figure 3b. A 2-bit remotely triggered switch [hardcoded (0,1)].

The major drawbacks of the above solution are both fabrication cost and size. The transformer solves both of these problems by replacing both the transformer and the filter in Figure 3a with a single, low cost micro-acoustic component. Then, a truly passive, addressable, remotely triggered switch would be as follows.

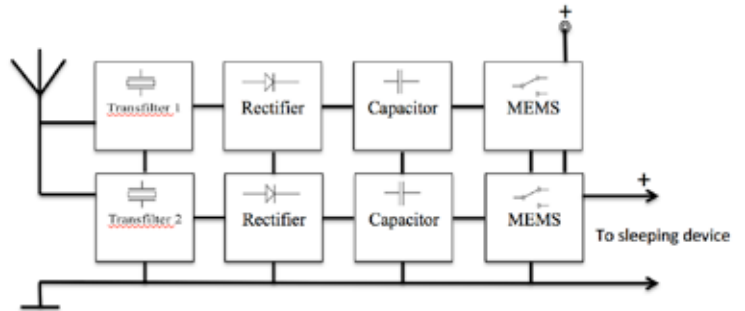

Figure 4. A 2-bit remotely triggered switch

Clearly, the switch illustrated in Figure 4 is truly passive and addressable (the two transfilters have non-overlapping passbands). The address is defined in a digital form by the sequence of MEMS switches which consists of both “normally open (“1”) and normally closed (“0”) MEMS switches. Certainly, a semi-passive version of the RTS

would use low threshold logic instead of the MEMS switches (as illustrated in Figure 3b). The maximum number of bits is defined by the ratio between the width of the band used and the width of a single channel.

Both passive and semi-passive RTS are suitable for use in “stand-by” units (such as “wake up radios” in wireless sensor networks and home electronics, RFID tags, etc). As a stand-alone component the transfilter can be used for EM power scavenging, impedance matching element, etc.

For more information contact
Prof. I.Katardjiev, Uppsala University,
email: ilia@angstrom.uu.se



RADIO FREQUENCY IDENTIFICATION DEVICES APPLIED IN STORMWATER FILTERING SYSTEMS

Since about 3 years CAMTECH FILTER AB has developed a unique and close to the market solution for addressing the pollution problems related to storm water dwells.

INTRODUCTION

EU has since several years enforced a so called water directive to ensure good water quality.

CAMTECH FILTER AB presents a product that is capable to filter all 32 of the most unwished chemical and heavy metal molecules. On top, the filter is equipped with a totally integrated electronically communication system (RFID technology) that can collect all relevant and detailed info and have centralized so that one single operator can review the status of hundreds of filter. The survey could also supply precious indications such as the CO₂ level around the filter (not demanded by the EU) Camtech has been able to

built up a kind of R&D program where KTH, one of the highest level technological research institute takes care of testing the efficiency of the filter and to encapsulate all the electronics.

Regarding patents, Camtech is now finalizing patents that will be extended worldwide.

Camtech has been also modelising all the fabric process and the logistic item.

The objective of CamTECH Environment Work is to create sustainable management of it's environment products through advancing our knowledge of interactions between products and the climate and developing new

technologies, tools and services in order to deliver an fully integrated stormwater filter product.

The concept of using sensors and RFID communication, combined with Cam Tech storm water filters. There are a number of sensors that can be relevant! A master node indicates the relative position from a GPS (see slave-node in the description for each position of the wells below).

The master node and the Slave node has sensors that indicate the area's conditions in terms of temperature (O: -40 ~ 120 ° C with an accuracy of ± 0.3 ° C at 25 ° C). As an option, although the O₂ Oxygen, Carbon Dioxide CO₂ and relative humidity measured.



These sensors provide an indication of the environmental conditions on the location of the plant. As a further option you can connect to sensors for Ethylene / combustion gases (called combustion gas sensor that apply within the lower order alkanes, alkenes and acetylene, carbon monoxide and hydrogen)

RFID IN GULLIES FILTERS AND AIDC DIAGNOSTIC ANALYSIS

This project aims to transfer and exploit the radical data carrier and item-attendant data-management benefits offered by radio-frequency identification (RFID) technology. The concept of using sensors and RFID communication, combined with Cam Tech stormwater filters from the filter-manufacturers to the gullies filter-users. The technology is applicable both to manufacturers, where the item-attendant data capacity can improve the efficiency. The usages in the processes in the end-users gullies where the RFID tags will provide the



capability for enhanced asset management and maintenance. It will also give the potential for remote monitoring and diagnostics, intelligent distributed control and functional control strategies through integration with the usual maintenance procedure in the communities.

RECIPIENT SECTORS

The recipient sectors identified for the transfer of RFID technology transfer

include both manufacturers and end-users of filters and filter systems from all the major sectors of the storm water market, as identified in Table 1. The total value of each sector is represented by total sales in 2013-2015 expects to be more than millions of filters.

The project is made up from Filter Manufacturer CamTech and the RFID Systems Integrator Retorium AB in co-operation with the iPack institute at the Royal Institute of Technology (KTH) in Kista Sweden. The technologies, which are common to most all market sectors, will be identified by the group to reflect the primary needs for technology transfer into the filtering market.

FILTER MANUFACTURERS / END USERS

The filter manufacturers and end-users identified in Table 1 are involved in the usage of the appropriate RFID technology.

COMPANY	BRIEF COMPANY PROFILE
CamTech Filter system	Leading manufacturer of progressing filter systems with a focus range of products to handle a diverse variety of liquids in stormwater gullies for polluted water and waste, chemical & oil exploration.
Retorium AB	RFID Project management and implementation system provider offer testing, research, spares and service.
iPack institute KTH	High school university with R&D science services in the KTH (The royal high school of technology) with lab and development capacity for RFID and sensor technology.
The community sectors	The local community's the have to implement this type of systems in all of Europe. It is approximately 10 million gullies only in Sweden, and The UEU directive states that this problem has to be solved by 2018.
Factory's and risk establishment's	These sectors are using filters to prevent pollution of substance and chemicals harmful to the environment. This is currently the world's largest user of waste separation today. The manufacturer needs to solve these problems thru their own R&D and their own spares and service.
Storm Water maintenance operators	The storm water maintenance teams has to handle each gullies every year and keep the system free from substance the influence on the free flotation of water – thru the filter manufacturer solutions this organisation who operate this tasks can provide the service of changing and destroying the used filters. These facilities can offer replacement, testing, maintenance, spares and service in the established organisation.

Table 2A: Filter users and Mechanical filter Manufacturers.

For further information please call:
 niels@camtechnology.se
 lucas@retorium.com

HRAFN PROJECTS FEATURE NORDIC ID TECHNOLOGY BROKER AND STANDARDISATION EXPERT CHOOSES NORDIC ID



HRAFN is Scandinavia’s leading RFID systems designer and architect. They provide advice, knowledge services and sometimes solutions for major players in a variety of industries including retail, oil and gas, transportation and logistics, construction and manufacturing. HRAFN — meaning ‘raven’ in Norse (Norse = Norwegian mythology) — designs systems with an emphasis on tracking assets’ life cycles, not just the process itself. The company does its best to follow EPC Global’s architecture framework and to use EPC Information Service (EPCIS) for traceability in the solutions they design.

“We focus on ideal systems design,” says Geir Vevle, the company’s CTO. “We don’t rely on the same partners time after time as a matter of course — we’re vendor agnostic. Instead we choose the optimal partners and suppliers for the project and for customer needs.”

BUILDING PREFERENCE FOR NORDIC ID

For a vendor agnostic company, HRAFN has chosen to work with Nordic ID quite a few times. Vevle attributes this to the quality and functionality of Nordic ID products. “What I particularly

like about Nordic ID mobile computers is the ability to read long, short and medium ranges with the same platform and only changing the configuration,” he says. “Plus reading capability under adverse conditions is excellent.” Nordic ID has formed part of five HRAFN solutions over the past three years, all of them in Norway. Here are a few examples:

CASE: NORSK LASTBÆRER POOL

Norsk Lastbærer Pool (NLP) is a Norwegian food industry organization established to manage a nationwide

pool of millions of pallets travelling between more than 800 industry players. NLP is currently piloting an RFID portal system with a small group of member companies. “The total potential payout is huge,” says Tom Romanich, Marketing Manager at NLP. He estimates the cost of RFID portals at one fifth, on average, of what is now being spent on manual inventory counts. Other efficiencies, including lower pallet costs and improved logistics are some of the many other potential benefits. HRAFN decided on the choice of Nordic ID together with Lexit, the project’s



“At this point, every new company project provisioned with equipment from the new storage facility get equipment that is tagged”

system integrator. “We had a good experience with Nordic ID mobile computers and not such a good one with other brands,” says Vevle. Romanich has identified some kinks to work out with stationary readers on the project, but is entirely satisfied with Nordic ID readers.

CASE: BOGART

Bogart is a high-end fashion retail chain based in Trondheim, Norway. With thousands of items to manage, the retailer has been using Nordic ID mobile computers for the past three years, both for inventory purposes and to find items on the shop floor, with Geiger counter functionality. When Bogart follows through with an upgrade of its storewide IT network, it will extend RFID functionality across the chain.

CASE: REINERTSEN

Reinertsen is a major Norwegian civil engineering, construction, and petroleum industry supply company. As

part of a HRAFN-led effort to improve logistics, Reinertsen began affixing RFID tags to 4,000 pieces of equipment in January 2011. By tracking the movement of high value items in and out of their storage area — including pumps, generators, concrete vibrators and other electrical devices — Reinertsen was able to make better use of assets and improve the accuracy of construction site equipment orders.

“At this point, every new company project provisioned with equipment from the new storage facility get equipment that is tagged” says Vevle. “The next phase involves better control of remote projects, by tracking everything while it’s on site.” To date, Reinertsen has made use of the Nordic ID Merlin mobile computer with Cross Dipole antenna, as well as the Nordic ID Morhic.

For further information please contact
mirva.saarijarvi@nordicid.com

“What I particularly like about Nordic ID mobile computers is the ability to read long, short and medium ranges with the same platform and only changing the configuration”

SCANGREEN INTRODUCES THE MORPH STICK: LATEST SCANNER FOR CC RFID TAGS (RED PADLOCKS) - OFFERS QUICK AND ACCURATE SCANNING WITHOUT BENDING

In January 2011 Container Centralen (CC) introduced RFID tags on the European CC Containers. The primary objective of this RFID tagging operation is authentication, which all CC Container users at every transfer are performing with RFID readers. Since the introduction of the RFID system Mieloo&Alexander have offered advice for the green sector. They have also developed the RFID tag scanners especially for CC under the brand name ScanGreen. The "Scan Green Morph Stick" is the latest scanner developed specifically for the green sector.



The ScanGreen Morph Stick is based on the Nordic ID Morphic UHF RFID Cross Dipole mobile computer, with an external "near-field" antenna on a light and adjustable stem. This device is great for scanning both loaded CC containers, as well as for scanning stacked CC chassis. This may be done with the Nordic ID Morphic on the handle, or with the stem in one, and the Nordic ID Morphic in the other hand. Sander Merckx (CEO of Mieloo & Alexander) comments: "the big-

gest challenge in reading the CC tags comes from 'cross-reads'. It is very hard to find the right balance between reading a single tag without the adjacent CC cart and reading a complete stack of empty carts. Using low power a single tag can be identified and authenticated but – as the tags are located in the lower edge of the trolley - you would have to bend down all the time. With the Morph Stick the daily operations become more comfortable".





THE ADVANTAGES:

- Light, fast and easy to use - scanning without bending down!
- High performance scan. It is able to scan weak tags, in that case the tag needs to be within 5 cm of the antenna head.
- Certified by Container Centralen for the authentication of the red padlocks on the CC containers.
- Maximum battery use time will be 4 hours non-stop scanning - load the scanner with a charger, a car charger or cradle that includes a spare battery that can be charged separately.
- Standard equipped with the ScanGreen software for authentication, scanning loaded CCs, scanning stacks. Expand to complete ScanGreen Container Management software.
- Based on industrial Nordic ID Morpich UHF RFID Cross Dipole mobile comouter (Windows CE 6.0, 1D laser barcode, BT, WLAN, UMTS/3G and GPS optional)
- Easy to integrate with ERP and / or packaging administration software, is already suitable for SDF and BOSS GO! applications.

WHAT USERS SAY ABOUT IT:

- Paul, manager fust hal, Baas Planten Service: "Works well!"
- Jhim, DC Coordinator, Baas Planten Service: "Of all the scanners that we have had, this is just what you want!"
- Pot and bedding plants nursery, Flevoland: "Scans good, fast and very accurate! If I have to choose between all the scanners that we currently have for our processes to support, the Morph Stick is by far the best due to the fact that this scanner provides all the combinations that we need."

**DO YOU HAVE
INTERESTING INFORMATION ABOUT RFID?**

Please contact: Ove.Canemyr@trendsetter.se

THE GOLDEN TAG AWARD 2012



THE SWEDISH FISH PROJECT APPLICATION FOR THE GOLDEN TAG AWARD 2011

SCOPE: GOVERNMENT PROJECT FOR RFID IMPLEMENTATION IN THE COMPLETE SWEDISH FISH INDUSTRY

CUSTOMER: SWEDISH BOARD OF FISHERIES (SWEDISH AGENCY FOR MARINE AND WATER MANAGEMENT)

SUPPLIER: ROI4U

SUMMARY:

In 2010 the Swedish Board of Fisheries were looking for a solution to meet the new European regulations about traceability of fish, from catch to consumer. Roi4u (a Swedish consultant company) introduced them to RFID and invited them to a project called eTrace to find out if EPCIS was a good standard for food supply chain traceability. eTrace proved it well, and the government started a project in late 2010 and over 2011 to set the rules, standards, technology etc in place for Sweden and the Swedish fish industry with Roi4u as project manager, Lund University for academic studies and reports, IBM for Government structures and GS1 for standardization

THE REGULATION:

EU1224/2009 is about traceability of Cod and three more species until 2013 and all species in Europe until 2015, from catch to sales, to production, to distribution, to retail and to

consumer. The Government in Sweden has a control roll to make sure that this will happen (in Sweden)

THE GOALS:

1. Meet the regulation.
2. Increase business value to the industry.
3. Better information to consumers.

The project: To set up a platform of RFID technology, standards, test&trials, prices&roi's to help and support a Swedish high volume rollout in short time. The project has tried to cover everything from high level infra structure down to low level issues like paperface material on RFID labels. We have tried to find the best hardware and software and tried a lot of them to support the industry

The reference group: To get the industry involved we invited them to a reference group in the project team. Each



chairman from all the different industries in fishery were in the group, from the Fishermen organization to the Fish Retailers organization, and have been adding a lot of good inputs to the project

TESTS AND TRIALS:

To support the coming rollout, several tests have been made. These tests have been public and general to bring in information about how to implement RFID in a high volume, see the pictures for some examples. These tests have also served another purpose; each fish company in Sweden can get the information and do not have to invest in high cost pre-studies and development projects

TECHNOLOGY:

We Technology: We have found that UHF RFID according to EPC is a mature standard that works very well in a harsh environment like the fish industry. As a standard for traceability we found that EPCIS is a very suitable standard that can be implemented in a quick and easy way, and brings a real time visibility to complicated supply chains

HOW IT'S DONE:

With RFID on returnable boxes today, each movement of the boxes (and what's in them) is reported to EPCIS, and made available for each partner in the supply chain as well for the government. Each box is a unique individual and the read points only read the

EPC number. So it's only traceability information in the system, no values or invoice information

THE RESULT:

We now have a well defined rollout plan for the industry in Sweden and the work has started. The solution also means a huge reduction of paperwork, both for the industry and for the Government. We can see that Sweden will be among the first countries to implement the new regulation and we have had some very good feedback from all over Europe in the way we have set up the plan and the way we have included the industry

Some examples:



Boxes with RFID at the fish auction in Gothenburg



Weight scale with RFID and EPCIS report



RFID on mobile phones used by fishermen and retailers

Box movements

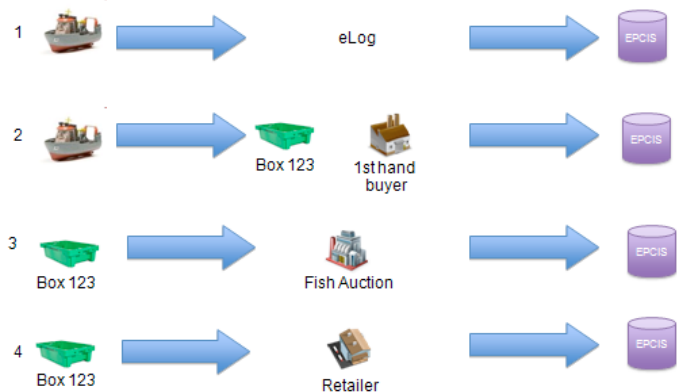



RFID IN EUROPE PLANS FOR 2013

Dear All,

As you read this new edition of the RFID in Europe Magazine, the network is fast approaching its first year in operation as a not-for-profit organisation. As well as ensuring that the structures for longevity are in place for the organisation, the Management Board members have also been working hard to provide deliverables to you, the members.

A process entitled **The Future Outlook** was initiated late 2012 which aims to document the vision as to how the broad domain of RF identification (RFID, NFC, IoT, etc.) may evolve or look like in the future. Some of you will have participated in the process. Member participation is particularly important in all the networks activities and we look forward to your continued participation throughout 2013.

RFID in Europe has committed to conducting two RFID surveys a year as a continuation of activities in this area since 2009. One of these surveys is currently activity. The aim of the survey is to monitor: (a) the RFID deployment status across Europe and (b) the interest and perceptions of European organisations regarding the technology. Information such as this is really valuable for the RFID industry itself. A further description of the survey and how you can assist us in maximising the number of respondents is covered in the next pages.

The strength of the network will be determined by a number of criteria and in particular the number of members, increased member participation, as well as the services that the network provides to its members. To this end the Management Board is committed to ensuring that we provide the services that will help in your business. RFID in Europe has committed to the following at a minimum for 2013:

- **2 x RFID in Europe Magazines per year, thanks to Ove Canemyr, RFID Nordic**
- **2 x Surveys per year, thanks to Andriana Dimakopoulou and Katerina Pramadari of the AUEB in Greece**
- **An RFID in Europe Event, which will take place later this year**
- **Services for Academics – including a call for papers**

If there are other services that you would like to see RFID in Europe provide we would be delighted to hear from you.

So keep checking in on our website (www.rfidineurope.eu) and our LinkedIn group to keep up to date with RFID in Europe. If you are not currently a member it is free to join and you can do so on our website also.

Until the next time, I wish you the best in your 2013 RFID pursuits.

Sincerely Yours,

Dr. Pat Doody
Management Board Chair – RFID in Europe
pat.doody@ittralee.ie

RFID in Europe AISBL is a not-for-profit organization established in 2012. RFID in Europe's principle goal is to promote the adoption of Radio Frequency Identification and related technology solutions enabling small and medium sized organizations throughout Europe to gain competitive advantage through their best use. RFID in Europe connects with European end-users, operators, solution providers, universities, research establishments, non-government and government organizations and all other European stakeholders through own initiatives and promotion of national projects via our international network. RFID in Europe is an extension of a European Commission FP7 Thematic Network called RACE networkRFID initiated in 2009. <http://www.rfidineurope.eu/>

RFID IN EUROPE CONDUCTS SURVEYS FOR THE EUROPEAN RFID MARKET

One of the main activities that the RFID in Europe network undertakes is to conduct annual European Surveys on RFID. RFID in Europe network runs for a second continuous year a survey with the aim to monitor: (a) the RFID deployment status across Europe and (b) the interest and perceptions of European organisations regarding the technology. The respective results have been published in papers and newsletters and presented in conferences in RFID (e.g. RFID in Europe conference in Prague, Athens, Brussels).

Some of the questions which are addressed in the survey are the following:

- Is RFID technology on the industry's priority list?
- What is the current market status and investment interest?
- What is the level of familiarity with RFID?
- Do companies gain advantage and save costs by investing in automatic identification?

- What is the most popular RFID application?
- What is the perceived value derived from the implementation of RFID?
- Do the end-user companies have the capabilities to implement RFID?
- What are the RFID implementation barriers that the organisations face?

If you want to find answers to these questions, you can participate to the following survey conducted by the RFID in Europe Network. Just click on the link below and complete the respective questionnaire. This is expected to take you 8-10 minutes and at the end you will be able to see a summary of all the responses.

<http://www.rfidineurope.eu/RFIDSurvey2012>

After completing the survey you'll get a detailed report of the survey results

You can contribute to the network's activity in two ways:

You can participate in the survey & distribute this survey link to your network!

RFID IN EUROPE

FUTURE OUTLOOK 2018-2023



Today an apparent gap exists which is considered by a number of RFID in Europe group members to be possibly influencing European RFID adoption and development.

The void referred to is the lack of a documented vision as to how the broad domain of RF identification (RFID, NFC, IoT, etc.) may evolve or look like in the future. Without such a reference many stakeholders including policy makers, potential and existing technology end users and others lack any kind of reference collective vision as to the future direction of RF identification. This initiative aims to stimulate investment confidence, whether that is within areas of R&D or application deployment.

This, the first Future Outlook was open to anyone and, indeed it was actively supported by a number of industry as-

sociations. The objective is to provide everyone an opportunity to contribute their visions, arranging these un-edited texts into a structured document allowing it to be easily read. Initial feedback at the launch of this initiative was overwhelmingly positive with more than 40 offers of contributions. The reality of structuring thoughts coherently in predicting the future and placing these into words undoubtedly had a dramatic effect upon the final number of contributions received. Nevertheless the contributions submitted were well prepared providing worthwhile reading. Additionally this first Future Outlook places a 'stake-in-

the-ground' and an important reference for a version 2 which is scheduled for development in 2014.

The Future Outlook is available on the RFID in Europe Web site (<http://www.rfidineurope.eu/>) from February 8th, 2013.

For more information please contact Trevor Peirce, Public Policy Leader & CFO, RFID in Europe AISBL (trevor.j.peirce@hotmail.com).